

FLOMORE

Different By Design

3800 Series Injector

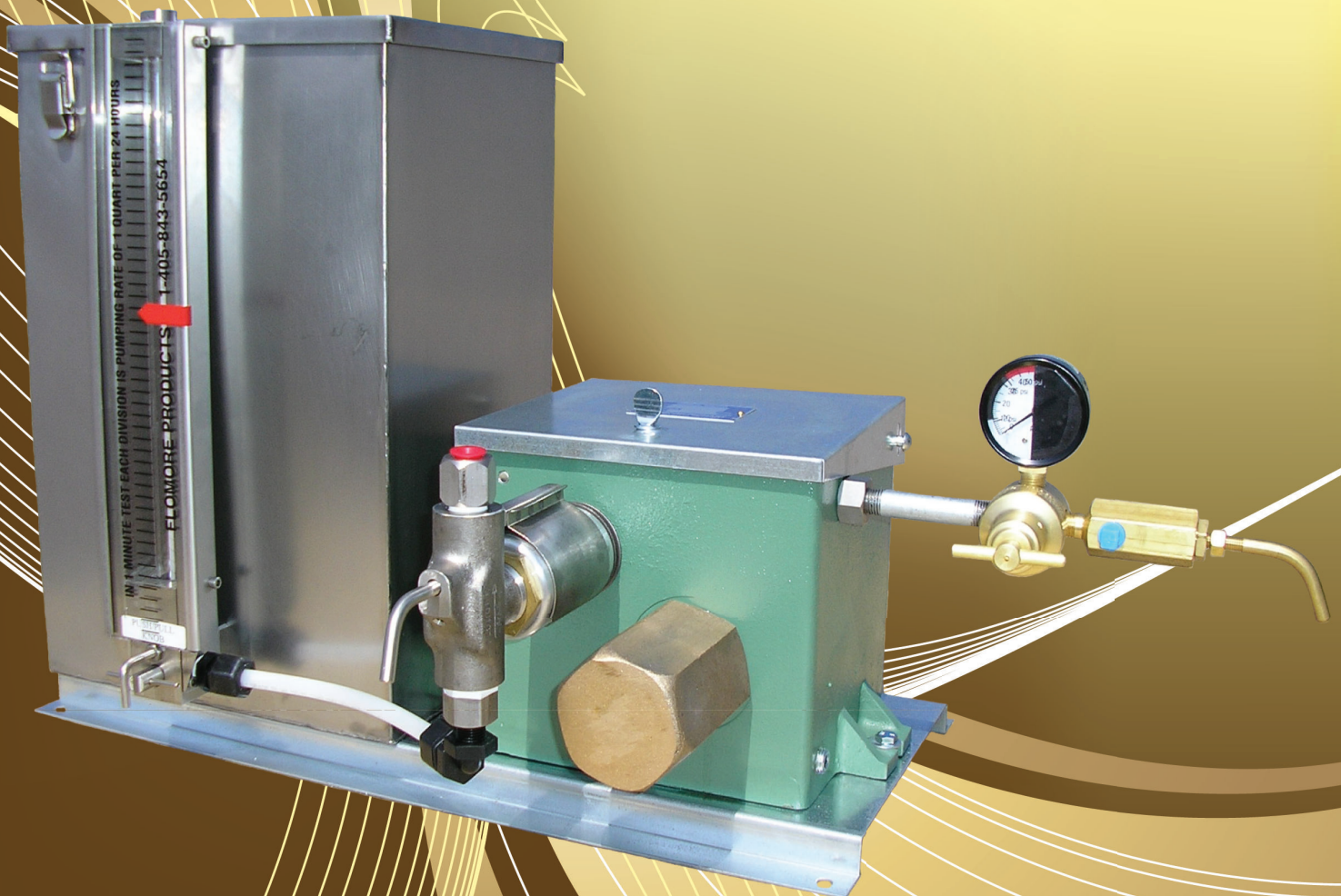

3800 Series Injector

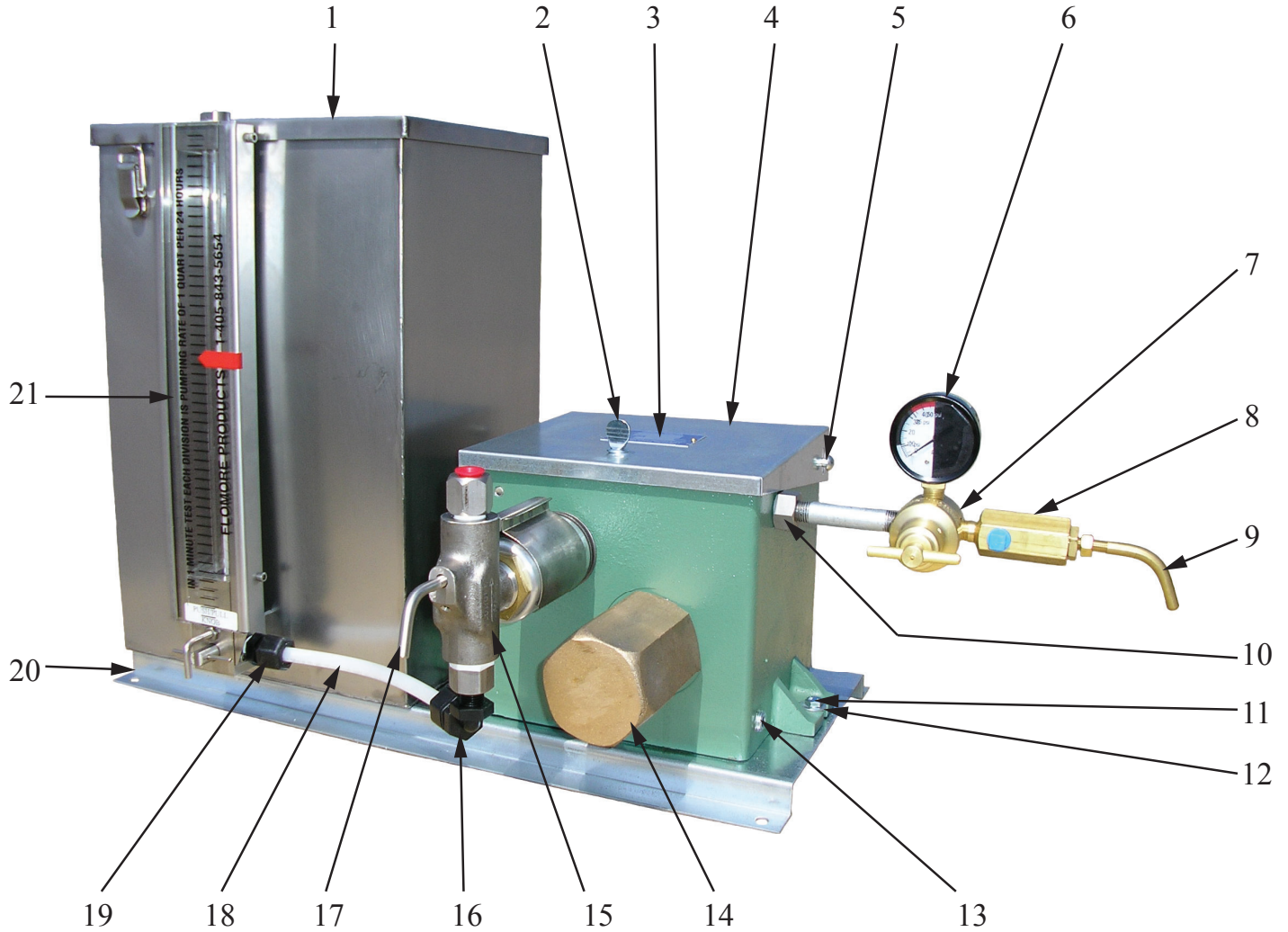

Parts List

Item #	Part #	# Reqd.	Description
1	A-0664	1	5 Gallon 430 Stainless Steel Reservoir
2	A-0575	1	Thumb Screw
3	A-0172	1	Nameplate
4	B-0206	1	Injector Box Cover
5	A-0528	2	Cover Rivets
6	A-1295	1	Pressure Gauge 0-100 PSIG
7	B-0040.01	1	Pressure Regulator
8	A-0193	1	Needle Valve & Stem Assembly
9	A-0013	1	Stem
10	A-0866	1	Inlet Bushing

Item #	Part #	# Reqd.	Description
11	A-0144	2	Hex Nut
12	A-0142	1	Hex Bolt
13	A-0138	2	Drain Plug
14	A-0390	1	Cylinder Shell
15	See Page 6	1	Injector Heads
16	A-3116	1	Elbow & Comp. Nut
17	A-1497	1	Priming Valve
18	A-3117	1	Supply Line
19	A-3118	1	Connector Half & Comp. Nut
20	A-0584	1	Single Tank Base
21	F-0871	1	Model 2000 Tank Gauge

3800 Series Components

A-0675 & A-0676 Line Check

Parts List

Item #	Part #	# Reqd.	Description	Material
1	A-0678	1	Inlet Body	Brass
	A-1297	1	Inlet Body	303 Stainless Steel
2	A-1574	1	Washer	304 Stainless Steel
3	A-0479	1	O'Ring	Buna-N
	A-2580	1	O'Ring	Viton
4	A-0054	1	3/8" Ball	316 Stainless Steel
5	A-0391	1	Spring	Steel
6	A-0679	1	Outlet Body	Brass
	A-1296	1	Outlet Body	303 Stainless Steel

* Recommended Spare Parts

**A-0675 Only

***A-0676 Only

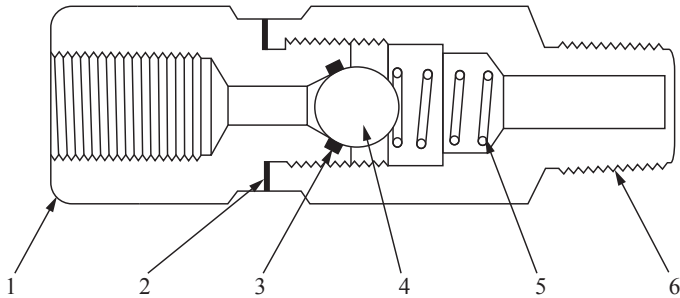

3800 Dimensions

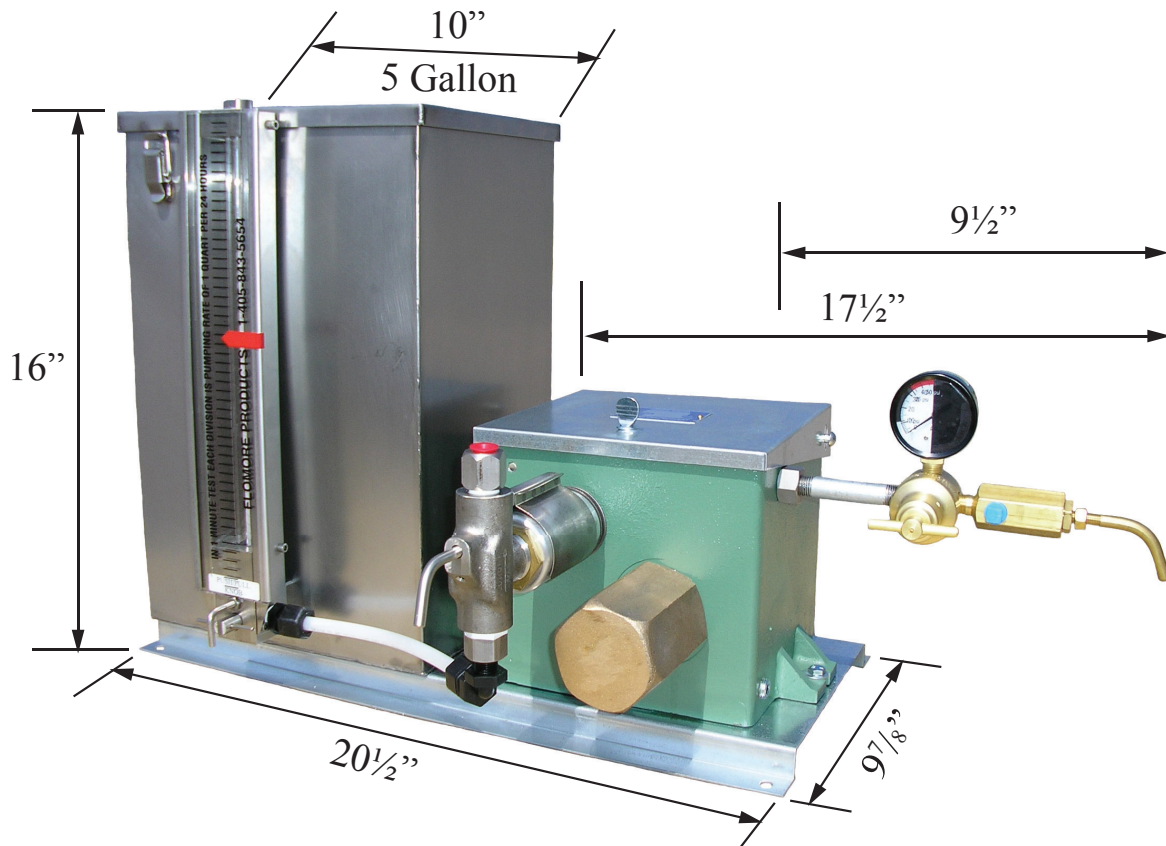

3800 Series Components

A-0193 Needle Valve & Stem

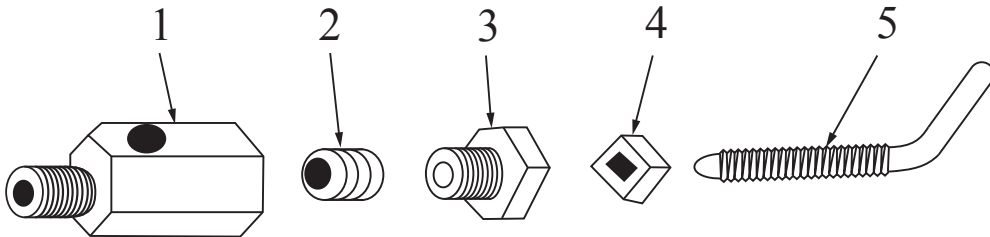

Parts List

Item #	Part #	# Reqd.	Description	Material
1	A-0010	1	Needle Valve Body	Brass
2	A-0023	1	Packing	Graphite
3	A-0011	1	Gland Nut	Brass
4	A-0195	1	Needle Valve Nut	Brass
5	A-0013	1	Stem	Brass

* Recommended Spare Parts

Cylinder & Piston

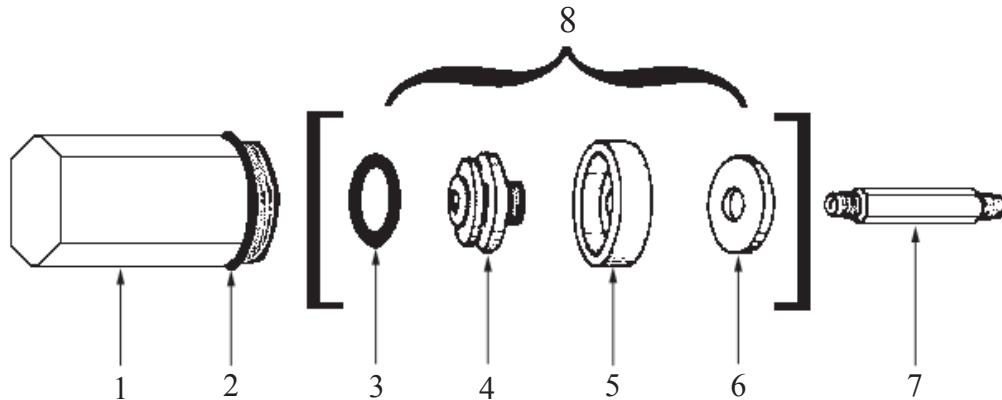

Parts List

Item #	Part #	# Reqd.	Description	Material
1	A-0390	1	Cylinder Shell	Aluminum
2	A-2457	1	O'Ring	Buna-N
3	A-0808	1	Cup Spring	Steel
4	A-1211	1	Cup Retainer	Aluminum
5	A-0867	1	Piston Cup	Leather
6	A-0890	1	Tapped Washer	Steel
7	A-0881	1	Piston Rod	Steel
8	A-0597	1	Piston Assembly	♦

* Recommended Spare Parts

3800 Series Components

C-0107 Valve Assembly

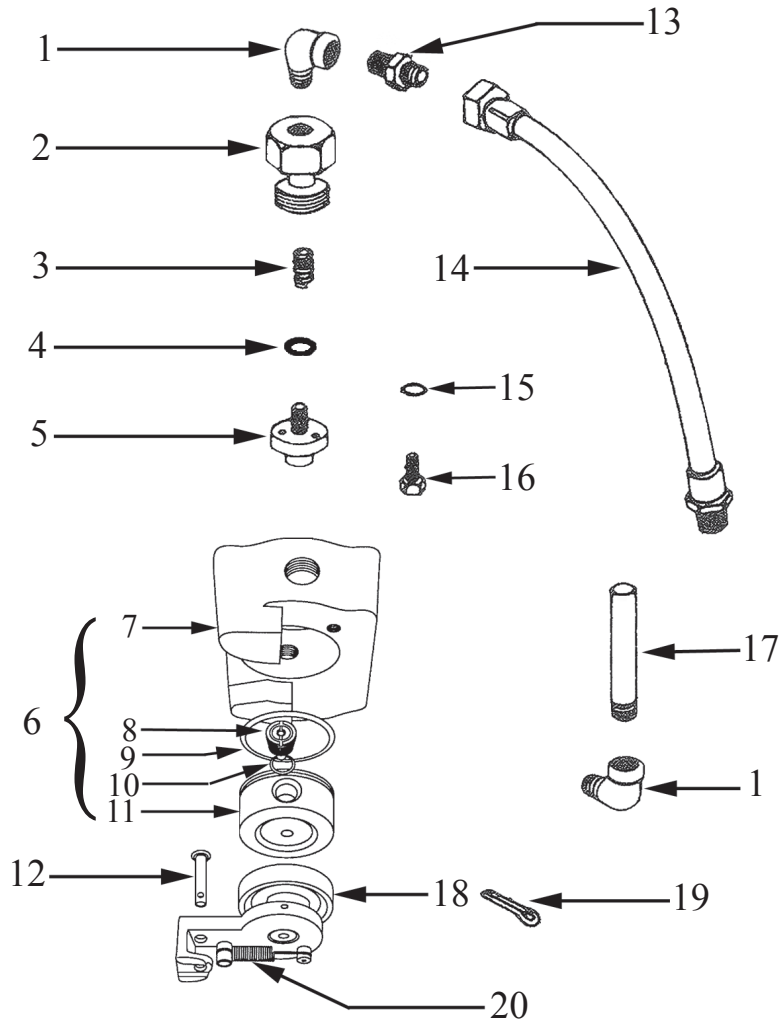

Parts List

Item #	Part #	# Reqd.	Description	Material
1	A-0578	1	Street Elbow	Galvanized Steel
2	C-0028.03	1	Bushing	Steel
3	A-0077	1	Spring	316 Stainless Steel
4	A-0579	1	Washer	Stainless Steel
5	A-4669	1	Valve Disc & Pin Assembly	Steel
6	C-0028	1	Pilot Valve Sub Assembly	◆
7	C-0028.02	1	Pilot Valve Body	Ductile Iron
8	C-0463	2	Seat Seal Screw	Steel
9	C-0485	1	Seat Seal O'Ring	Buna-N

Item #	Part #	# Reqd.	Description	Material
10	C-0474	2	Seat Seal Screw O'Ring	Buna-N
11	C-0028.04	1	Valve Seat	Steel
12	A-0170	1	Clevis Pin	Steel
*13	A-0137	1	Half Union	Brass
*14	B-0047	1	Gas Inlet Hose	◆
15	A-0167	1	Washer	Steel
16	A-3387	1	Cap Screw	Steel
17	A-0761	1	Exhaust Nipple	Steel
18	A-0065	1	Flipper Arm Assembly	◆
19	A-0168	1	Cotter Pin	Steel
20	A-0508	1	Flipper Spring Assembly	Steel

* Recommended Spare Parts

* Items Sold Separately

3800 Series Components

Ratchet Drive

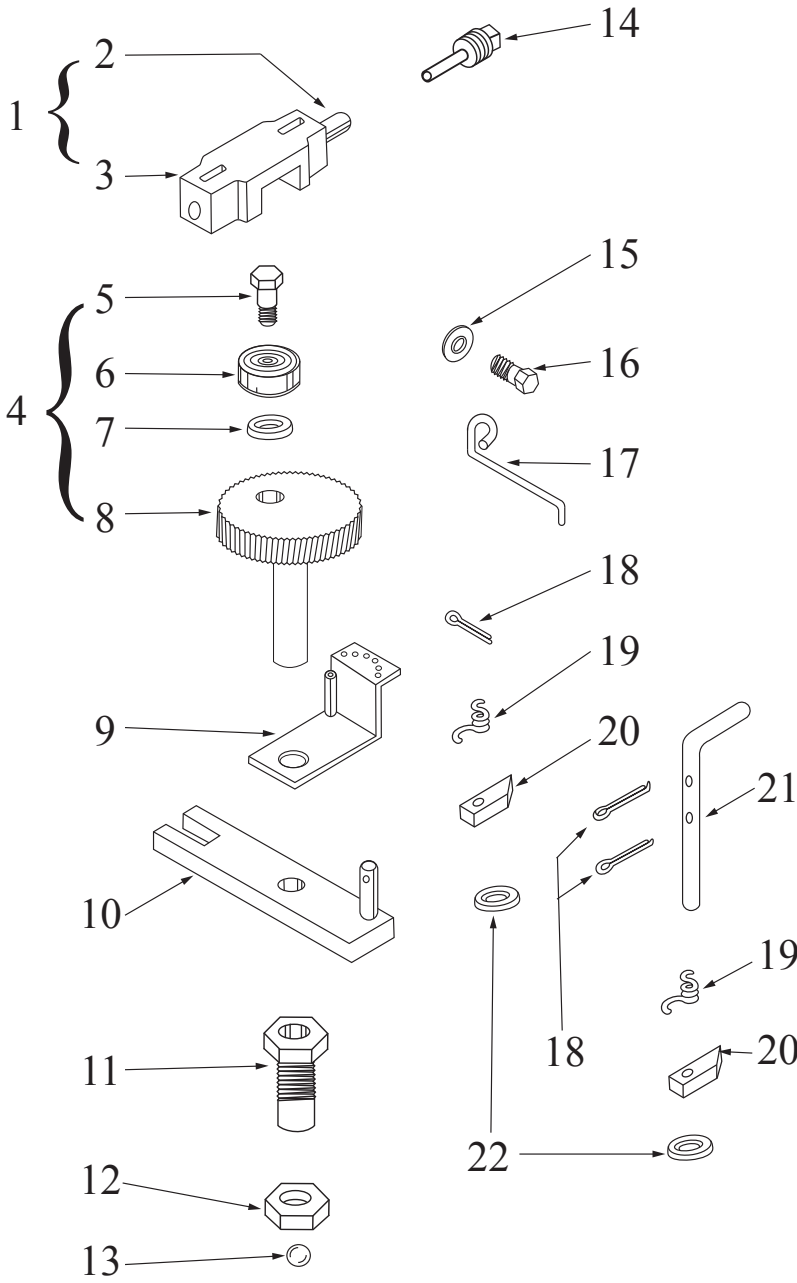

Parts List

Item #	Part #	# Reqd.	Description	Material
1	A-0585	1	Cross Head Assembly	Steel
2	A-0883	1	Guide Sleeve	Brass
3	A-0939	1	Cross Head	Steel
4	A-0586	1	Ratchet Sub-Assembly	Steel
5	A-0433	1	Bearing Bolt	Steel
6	A-0457	1	Ratchet Bearing	Steel
7	A-0458	1	Washer	Steel
8	B-0139	1	Ratchet Assembly	Steel
9	A-0948	1	Ratchet Control	Steel
10	A-0312	1	Cross Arm Assembly	Steel
11	A-0947	1	Bearing Insert	Steel
12	A-0107	1	Lock Nut	Brass
13	A-0126	1	Ball	316 Stainless Steel
14	A-0434	1	Guide Plug Assembly	Brass & Steel
15	A-0167	1	Washer	Steel
16	A-0574	1	Latch Bolt	Steel
17	A-0949	1	Ratchet Latch	Steel
18	A-2598	1	Cotter Pin	Steel
19	A-0955	1	Pawl Spring	Steel
20	A-0455	1	Ratchet Pawl	Heat Treated Steel
21	A-0956	1	Check Pawl Stud	Steel
22	A-0577	1	Washer	Steel

* Recommended Spare Parts

3800 Series Components

F-0871 Tank Gauge

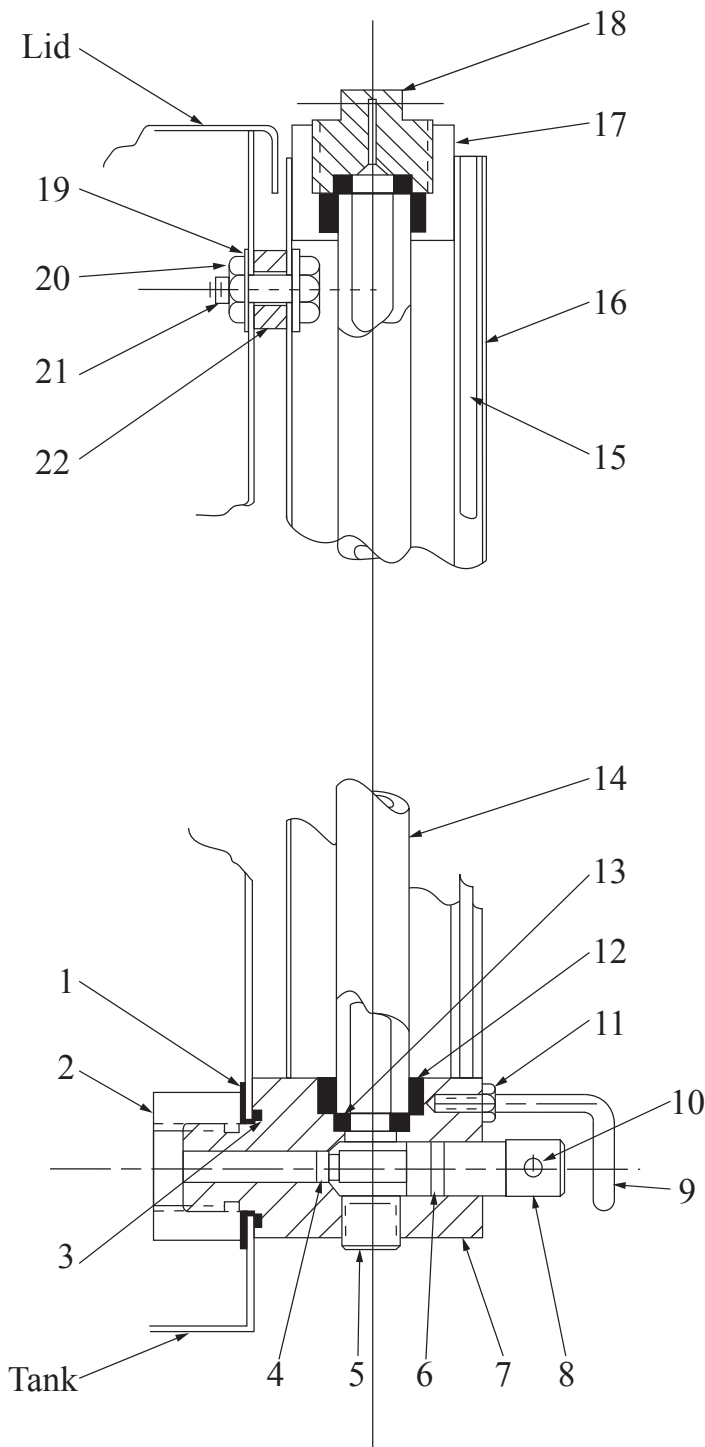

Parts List

Item #	Part #	# Reqd.	Description	Material
1	A-0306	1	Washer	Teflon
2	F-0871.01	1	3/4-16" Nut	Stainless Steel
3	F-0871.03	1	2-019 O'Ring	Viton
4	F-0871.04	1	2-006 O'Ring	Viton
5	A-0138	2	1/4" NPT Pipe Plug	Steel
6	F-0871.06	1	2-011 O'Ring	Viton
7	F-0871.07	1	Valve Body	Stainless Steel
8	F-0871.08	1	Valve Stem	Stainless Steel
9	F-0871.11	1	Valve Stop	Stainless Steel
10	F-0871.09	1	1/8" x 2" Roll Pin	Stainless Steel
11	F-0871.10	1	Valve Stop Nut	Stainless Steel
12	15470	2	Tube Gasket	Buna-N
13	D-0013	2	Tube End Seal	Viton
14	A-3102	1	Glass Tube	Glass
15	F-0871.15	1	Scale	Acrylic
16	F-0871.16	1	Housing	Stainless Steel
17	F-0871.17	1	Top Block	Aluminum
18	F-0871.18	1	Vent Plug	Stainless Steel
19	A-4092	2	Stat-O-Seal	Steel
20	F-0871.20	1	1/4-20" Nut	Stainless Steel
21	F-0871.21	1	1/4-20" x 3/4" Bolt	Stainless Steel
22	A-0987	1	Spacer	Stainless Steel

Injector Heads

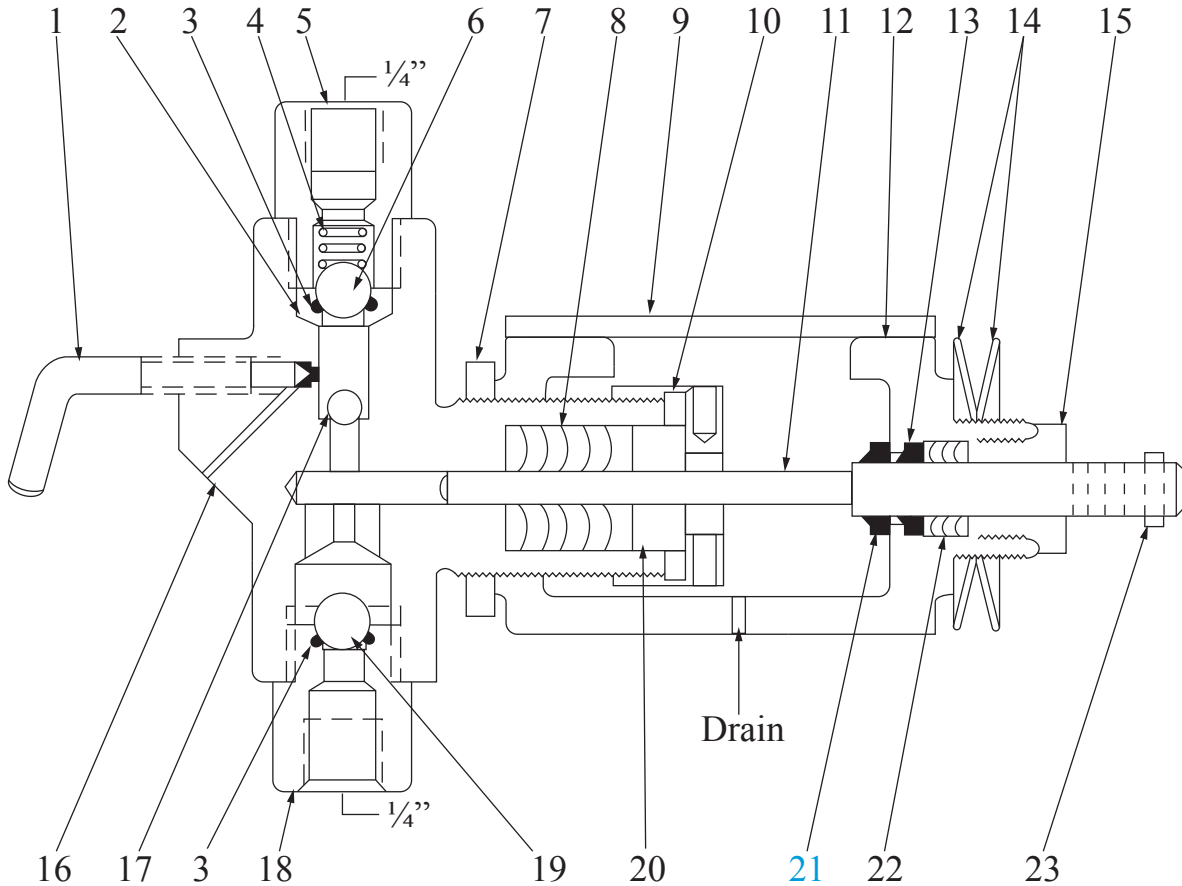

Note: Drip Ring moves with the Plunger.

Alternate Construction

Item #	Part #	Description	Material
2	A-0806	Top Seat Assembly (Metal-to-Metal)	303 Stainless Steel
	A-0843	Top Seat with Viton O'Ring	
3	A-2580	O'Ring	Viton
8	A-4102	1/4" Plunger Packing	Viton
	A-1642		Teflon
	A-2295		Hard
	A-4101	3/8" Plunger Packing	Viton
	A-1234		Teflon
	A-1875		Hard
	A-4103	1/2" Plunger Packing	Viton
	A-1012		Teflon
	A-1874		Hard
	11	B-1175-C	1/4" Ceramic Plunger
B-1176-C		3/8" Ceramic Plunger	
B-1177-C		1/2" Ceramic Plunger	
18	A-0771	Bottom Seat Assembly (Metal-to-Metal)	303 Stainless Steel
	B-0844	Bottom Seat Assy. (Viton)	
19	A-0053	1/2" Ball	316 Stainless Steel

Injector Heads

Parts List

Item #	Part #			# Req'd.	Description	Material
	1/4"	3/8"	1/2"			
♦	C-1578	C-1579	C-1580	1	Head Assembly	Ductile Iron with Stainless Steel Trim
	C-1582	C-1583	C-1584			All Stainless Steel
1	A-1497			1	Priming Valve	303 Stainless Steel
*2	B-0737			1	Top Seat Assembly-Buna	303 Stainless Steel
*3	A-0479			1	O'Ring	Buna-N
4	A-0077			1	Ball Check Spring	316 Stainless Steel
5	A-1496			1	Top Bushing	302 Stainless Steel
6	A-0054			1	3/8" Large Top Ball	316 Stainless Steel
7	A-0225			1	Yoke Lock Nut	Brass
*8	A-1461	A-1456	A-0959	1	Plunger Packing Set	Buna-N
9	C-1604			1	Yoke Cover	303 Stainless Steel
10	A-4104			1	Plunger Packing Gland Nut	303 Stainless Steel
*11	B-1175	B-1176	B-1177	1	Plunger	17-4 pH Stainless Steel
12	B-1173			1	Yoke	Malleable Iron
13	A-4095			1	Plunger Wiper Ring	Buna-N
14	A-4256			2	Belleville Washer	302 Stainless Steel
15	A-4094			1	Yoke Packing Nut	Brass
16	C-0275	C-0276	C-0272	1	Body	Ductile Iron
	C-0291	C-0425	C-0349			Stainless Steel
17	A-0126			1	1/4" Small Top Ball	316 Stainless Steel
*18	B-0736			1	Bottom Seat Assembly- Buna	303 Stainless Steel
*19	A-0054			1	3/8" Suction Ball	316 Stainless Steel
20	A-1463	A-0957	A-1219	1	Plunger Packing Gland	303 Stainless Steel
21	A-4095			1	Plunger Drip Ring	Buna-N
22	A-4127			1	Yoke Packing Set	Buna-N
23	A-0290			1	Pin Plunger	Carbon Steel

*Recommended Spare Parts

*Alternate Components Available (see table above)

Plastic Injector Heads



Parts List

Item numbers below correspond with drawing on page 8.

Item #	1/4"	3/8"	1/2"	# Req'd.	Description	Material
---	C-1570	C-1571	C-1572	1	Head Assembly	PVC
1		A-1497PVC		1	Priming Valve	PVC
2		B-0737PVC		1	Top Seat Assembly	PVC
3		A-2580		1	O'Ring	Viton
4		A-0077		1	Ball Check Spring	316 Stainless Steel
5		A-1496PVC		1	Top Bushing	PVC
6		A-0054.01		1	3/8" Large Top Ball	Ceramic
7		A-0225		1	Yoke Lock Nut	Brass
8	A-2701	A-2801	A-2901.01	1	Plunger Packing Set	Buna-N
9		C-1604		1	Yoke Cover	303 Stainless Steel
10		A-4104PVC		1	Plunger Packing Gland Nut	PVC
11	B-1175-C	B-1176-C	B-1177-C	1	Plunger	Ceramic
12		B-1170		1	Yoke	PVC
13		A-4095		1	Plunger Wiper Ring	Buna-N
14		A-4256		2	Belleville Washer	302 Stainless Steel
15		A-4104PVC		1	Yoke Packing Nut	PVC
16	C-0271	C-0273	C-0274	1	Body	PVC
17		A-0126.01		1	1/4" Small Top Ball	Ceramic
18		B-0736PVC		1	Bottom Seat	PVC
19		A-0054.01		1	3/8" Suction Ball	Ceramic
20	A-2702	A-2802	A-2902	1	Plunger Packing Gland	303 Stainless Steel
21		A-4095		1	Plunger Drip Ring	Buna-N
22		A-4127		1	Yoke Packing Set	Buna-N
23		A-0290		1	Pin Plunger	Carbon Steel

*Recommended Spare Parts

Performance Data

Volume Output

*NOTE: Multiply volume by number of ratchet teeth engaged. Maximum number of teeth is six.

Cycles Per Min. Air Motor	*Ratchet Teeth Engaged	¼" Plunger			⅜" Plunger			½" Plunger		
		Short Stroke	Medium Stroke	Long Stroke	Short Stroke	Medium Stroke	Long Stroke	Short Stroke	Medium Stroke	Long Stroke
10	1	◆	◆	◆	◆	◆	◆	◆	◆	◆
20	2	◆	◆	◆	0.5	0.7	1.0	1.0	1.5	2.0
40	1	◆	◆	◆	0.8	1.5	3.0	1.2	3.0	5.3
60	1	0.5	1.0	1.8	1.1	2.6	4.5	2.3	5.0	8.2
80	1	0.7	1.4	2.6	1.7	3.7	6.0	3.2	6.7	10.5
100	1	1.0	2.0	3.4	2.3	4.8	7.7	4.3	8.7	14.0

Volume in Pints per Day

Pressure Volume Range

*NOTE: For double headed units, increase maximum volume by two.

Plunger Size	Maximum Discharge Pressure	Model #	Pints per Day	
			Minimum Volume	Maximum Volume
¼"	1500	38-01	0.5	16
⅜"	1000	38-03	0.5	40
½"	500	38-05	1.0	70

Air/Gas Consumption

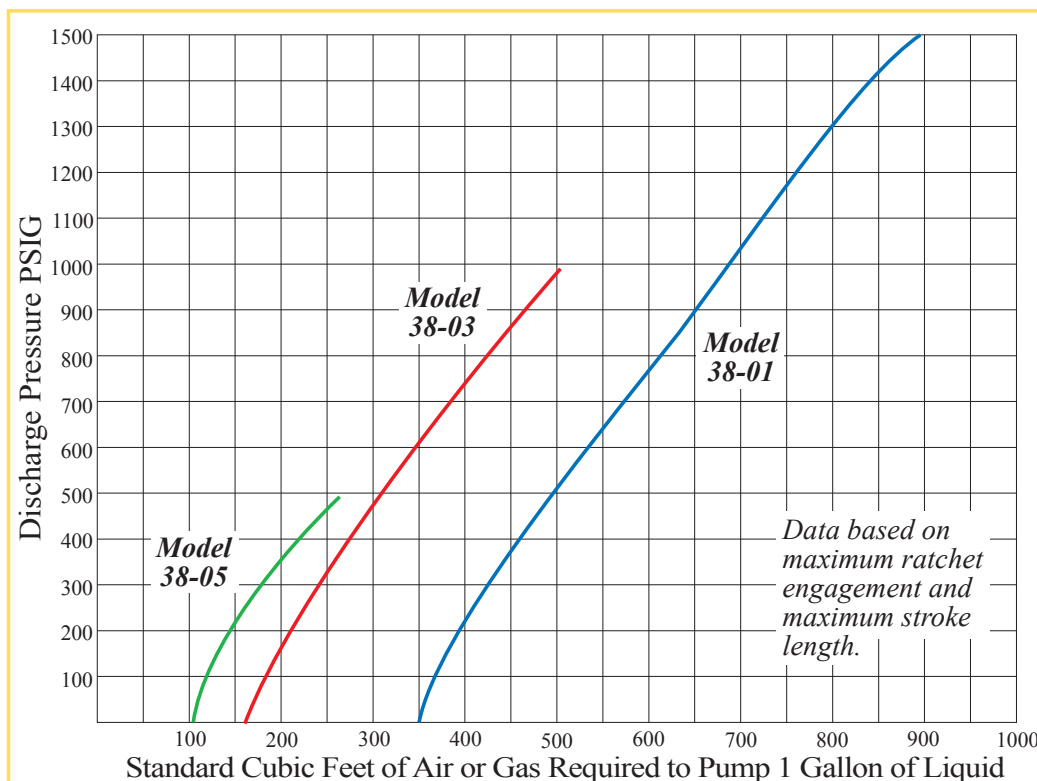

Volume Adjustment

Volume Adjustment

There are three principal adjustments involved in controlling injector volumes on the 3800 Series chemical injector. They are pointed out in the diagram at the right under the headings of Adjustments A, B and C.

Adjustment A:

1. Gas valve to control speed or number of strokes per minute of motor.

Adjustment B:

2. Ratchet control determines number of teeth drive pawl will engage each stroke of motor. Place ratchet latch A-0949 in the hole on the left to engage maximum number of teeth to pump maximum volume.

Adjustment C:

3. First position, long stroke (most volume).
4. Second position, medium stroke.
5. Third position, short stroke (least volume).

For maximum efficiency at any desired discharge rate, make adjustments in order **A-B-C**.

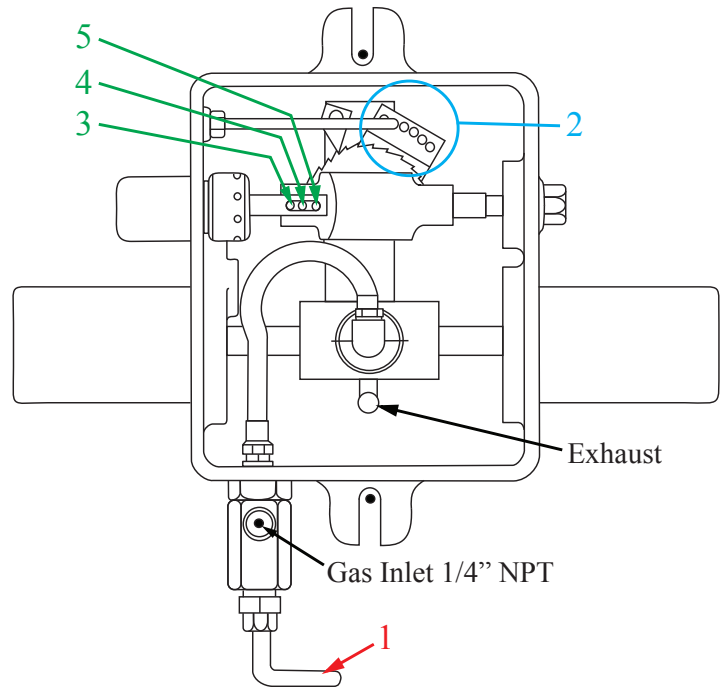

Installation and Operating Instructions

1. Remove pump from carton and inspect for possible damage in transit from factory. The cardboard carton was designed especially for this pump. If the pump has been damaged in transit, file a claim with the carrier.
2. Bolt holes are provided for a permanent mounting (see drawing for dimensions on page 3).
3. Install the A-1497 priming valve (included with pump, but shipped loose in carton) on the pump head.
4. Connect the suction line to pump head.
 - a. If a reservoir is furnished with the pump, the suction line is already connected. Fill the reservoir and open (all the way) the B-0871 shut-off assembly. A strainer is furnished as a part of this unit.
 - b. If a power unit model was purchased, a strainer should be piped into the suction line to prevent sand, rust or other particles which will injure the plunger and foul the check valves.
5. Connect the discharge line (5/16" copper tubing will suffice). An A-0676 1/4" brass line check is provided with most models. This valve should be installed as close to the point of injection as possible. Note the arrow on the check valve indicating the direction of flow. The top connection on the pump head is the outlet and has a 1/4" female pipe thread connection.
6. Connect the power gas line.
 - a. First blow power gas line clean to remove any loose rust particles, slag, sand, etc.
 - b. Consider the pressure requirements of the pump. If the gas supply exceeds 50 PSI (consider erratic pressures), the pump should be equipped with a regulator to reduce the gas pressure to 50 PSI or below. The B-0040 regulator is capable of handling upstream pressures to 1500 PSI.
 - c. Tie-in the gas line to the A-0193 needle valve or A-0866 inlet bushing.
7. Fill the A-0583 box assembly with enough SAE-30 oil to cover the A-0457 bearing (approximately 6 1/4 pts.) If low ambient temperatures are encountered, a lighter oil such as SAE-10 should be used. Check oil level at regular intervals with A-0946 oil gauge stick.
8. Adjust for desired volumes by considering Performance Data (page 11 & 12). If more volume is required, the pump head assembly can be changed or converted to a larger plunger size. Or, an additional head can be installed on the opposite side of the A-0583 box assembly by removing the A-0434 guide plug assembly. The A-0883 guide sleeve should also be removed and this can be accomplished with a drift and hammer.
9. Start the pump by slowly opening the A-0193 needle valve. Prime the pump head by opening the A-1497 priming valve. After the pump discharges clear fluid without bubbles, close the priming valve for normal operations. At this point make a visual check of the plunger drip, and using the A-0315 gland wrench that is included in the package, slowly tighten the gland to prevent excess drippage and waste of chemicals. **Do not overtighten plunger packing. Do not tighten with pressure on head.** Keep A-0315 gland wrench handy for future packing adjustment. It may be necessary to readjust the packing the next day. A slight leak during the break-in is beneficial. Sufficient time should be allowed to let the packing "seat-in".

If low volumes are being pumped, the pump head, the fluid discharge line and all other fittings up to the line check should be thoroughly purged of all air bubbles.

Check pump action by opening A-1497 priming valve.

Maintenance Instructions

To Inspect or Replace Power Cylinder or Piston Parts

Shut off the power gas pressure. Unscrew A-0390 cylinder shell. This will expose A-0597 piston assembly and A-0881 piston rod. To replace piston cup A-0867 or tapped washer A-0890, unscrew A-1211 piston cup retainer. A-0881 piston rod is hex material and is easily removed from C-0028 valve body.

To Inspect Pump Head Parts

Suction and discharge balls and seats can be inspected or replaced without removing pump head from the power unit. To do this it is necessary to disconnect suction and discharge lines at the head and unscrew A-1496 top bushing and B-0736 bottom bushing.

To Remove Pump Head From Gear Box

1. Disconnect suction and discharge line.
2. Pull A-0290 pin.
3. Entire fluid head can now be unscrewed from gear box.
4. Loosen gland nut.
5. Pull chemical plunger from head.
6. Remove A-0810 packing nut. This gives access to the yoke packing.
7. Loosen A-0225 lock nut. Yoke can then be unscrewed from fluid head (while unscrewing the yoke the gland nut must also be backed-off). At this point, wiper washer, gland nut and packing gland nut can be removed. This gives access to the main plunger packing.

To Replace A-0065 Flipper Arm Assembly and Bearing

Remove both A-0166 cap screws and S-0167 washer from the underside of C-0028 valve body. To remove A-0947 bearing insert, loosen A-0107 lock nut. A-0126 valve ball should be inspected and replaced if necessary.

To Inspect or Replace A-0457 Ratchet Bearing

1. First remove A-0434 guide plug assembly.
2. Then remove the pump head from the gear box (in case of double headed pumps, both heads should be removed).
3. A-0585 cross head assembly can then be lifted out. A-0457 ratches bearing and A-0458 washer can now be inspected or replaced by removing A-0433 bearing bolt. B-0139 ratchet assembly can now be lifted out.
4. A-0948 ratchet control can be disconnected from A-0949 ratchet latch and lifted out.
5. A-0312 cross arm assembly can be slipped from under the A-0793 bushing and lifted out. A-0455 ratchet pawl, A-0955 pawl spring, A-0576 cotter key and A-0577 washer can now be inspected or replaced.
6. A-0793 bushing can be removed exposing A-0077 ball check spring, A-0579 washer and B-0136 valve disc for inspection.

To Remove B-0107 Switching Valve

Remove both A-0390 cylinder shells. Unscrew both A-0881 piston rods (A-0597 piston assemblies may be left on the A-0881 piston rod). At this point B-0107 valve and A-0065 flipper arm assembly can be lifted from gear box. A-0508 flipper spring sub-assembly can be replaced by removing A-0168 cotter pin and A-0170 clevis pin.

To Replace B-0047 Gas Hose

Unscrew the hex nut (attached to hose) from A-0137 half union. Then unscrew B-0047 hose from A-0866 inlet bushing.

This page intentionally left blank

FLOMORE

Richart Distributors, Inc.

Corporate Office

3415 South I-35 Service Road
Oklahoma City, OK 73129
1-866-843-5654
Fax: (405) 619-3007
Richart@flomore.com

Dickinson Branch

533 East Villard Suite B
Dickinson, ND 58601
(701) 483-8267
Fax: (701) 483-8268

Kilgore Branch

Cardon Sales Company, LLC

820 South Commerce Street
Kilgore, TX 75662
(903) 984-3070
Fax: (903) 984-7901
THunt@cardonsales.com

Louisiana Branch

Cardon Sales Company, LLC

213 Cummings Road
Broussard, LA 70518
(337) 839-1704
Fax: (337) 839-1706
bcardon@cardonsales.com

Odessa Branch

Patterson Equipment Sales, Inc.

1610 S. Regal Avenue
Odessa, TX 79763
(432) 332-3345
Fax: (432) 332-3348
chad@pattersonsalesinc.com

