

FLOMORE

Different By Design

3500

Wolf Series

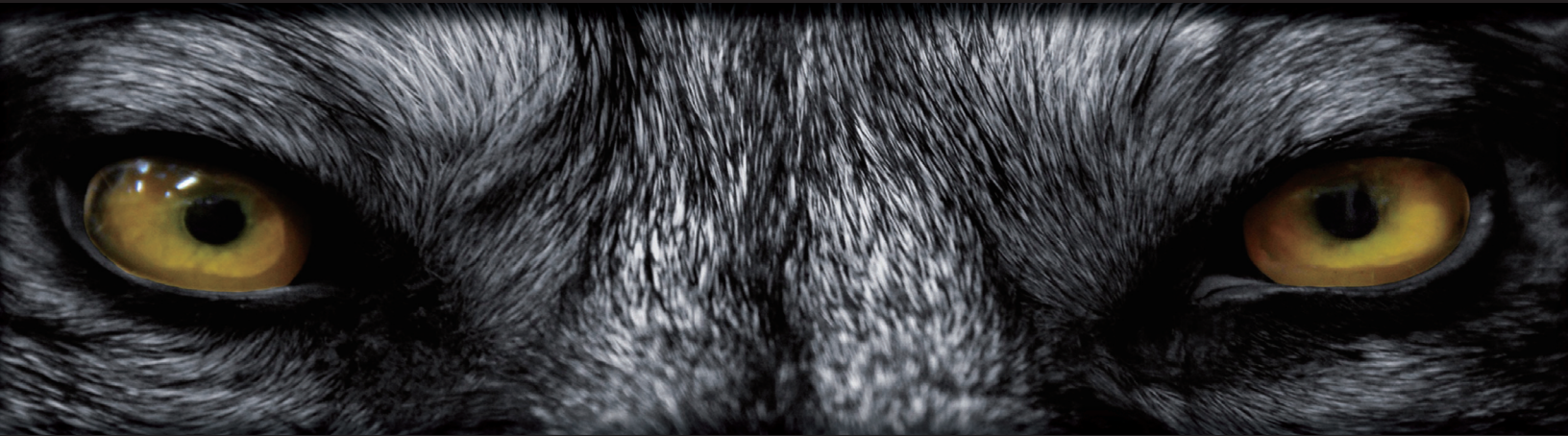

DUPLEX

3500 Duplex



*The Flomore 3500 series chemical injection pumps are electric driven, positive displacement pumps utilizing C-faced motors and common gear reducers. The gear reducers are available in 15, 30, 60, and 120 strokes per minute configurations. By utilizing even further flexibility of a wide variety of plunger sizes, the 3500 Series can fill many application requirements of different flow and pressures.

Additional Information

- Maximum discharge pressure:
6000 PSI (413 bar) with 3/16" plunger
- Maximum volume 139 gallons per day
(528 liters per day) w/1/2" plunger
- Head is adjustable while running
- Available Simplex and Duplex
- Available in four stroke rates:
15,30,60, or 120 strokes per minute
- 1/2 horsepower motor standard; 1 or 3 phase,
TFC or explosion proof; 50 or 60 hertz
- Available with 3/16", 1/4", 3/8", or 1/2" plunger

Model Designation

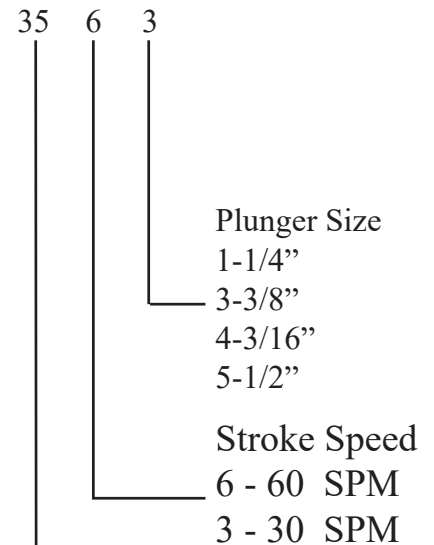

3500 Duplex Performance Data



**Patent Pending*

Model #	Plunger Size	Strokes Per Minute	Maximum Discharge Press(PSI)	Gallons Per Day (per head)	
				Maximum	Minimum
35-34SS	3/16"	30	6000	4.9	0.5
35-64SS		60	6000	9.8	1
35-31SS	1/4"	30	4000	8.6	0.9
35-61SS		60	4000	17.3	1.7
35-33SS	3/8"	30	1800	19.6	2
35-63SS		60	1700	39.2	3.9
35-35SS	1/2"	30	1025	34.8	3.5
35-65SS		60	1000	69.7	7

**Note, Performance Data Complies with both Simplex and Duplex Pumps.*

3500 Duplex Parts

Parts List

Item	Flomore Part #	Pcs Required	Description	Material
1	B-1483-DH	1	Cover	363F Aluminum
2	A-0136	3	Thumbscrew	Gr 5 Zinc
3	A-5963	1	Cover Gasket	Nitrile
4	C-2048-DH	1	Housing	356T6 Aluminum
5	A-0141	4	HHCS 5/16-18	Gr 5 Zinc
6	A-0144	4	Nut Hex 5/16-18	Gr 5 Zinc
7	A-0167	8	Cut Washer 5/16	Gr 5 Zinc
8	C-2197DH	1	Base Plate	Galv Steel
9	N/A	1	Head Assembly	316 SS
10	D-5964	2	Cross Head Bearing	Nylon
11	D-5965	2	Cross Head Bearing	Nylon
12	A-6935	1	Sleeve Bearing	Nylon
13	B-1542	2	Cross Head	316 SS
14	A-5823	2	Eccentric Cam	C1018 Steel
15	A-5830	2	Roller Bearing	Steel
16	A-5831	2	Set Screw	Steel
17	A-6386	2	Key	Steel
18	A-6936	1	Sleeve Bearing	Nylon
19	A-6714	1	Coupling	Steel
20	Gear Reducer	1	Reducer	N/A
21	A-5822	2	Stroke Adjustor	C1213 C.R.S
22	A-5824	2	Lock Nut , Stroke Adj.	416 SS
23	A-5825	2	Adjusting Screw	416 SS
24	A-5953	2	Drive Clip	Steel
25	N/A	1	Motor	N/A
26	A-0425	4	Lockwasher 5/16	GR 5 ZINC
27	B-1726.2	1	Drive Shaft	Steel
28	A-6720	1	Drive Shaft Key	Steel
29	B-1700	1	Coupling Guard	Steel
30	A-0139	2	HHCS 3/8-16x1.25	Gr 5 Zinc
31	A-2207	2	Hex Nut 3/8-16	Gr 5 Zinc
32	A-0746	4	Flatwasher 3/8	Gr 5 Zinc
33	A-0459	2	Lockwasher SPG 3/8	Gr 5 Zinc

** Items 1, 2 and 3 Indicate Pump Cover Components (not displayed in drawing)*

Parts Drawing

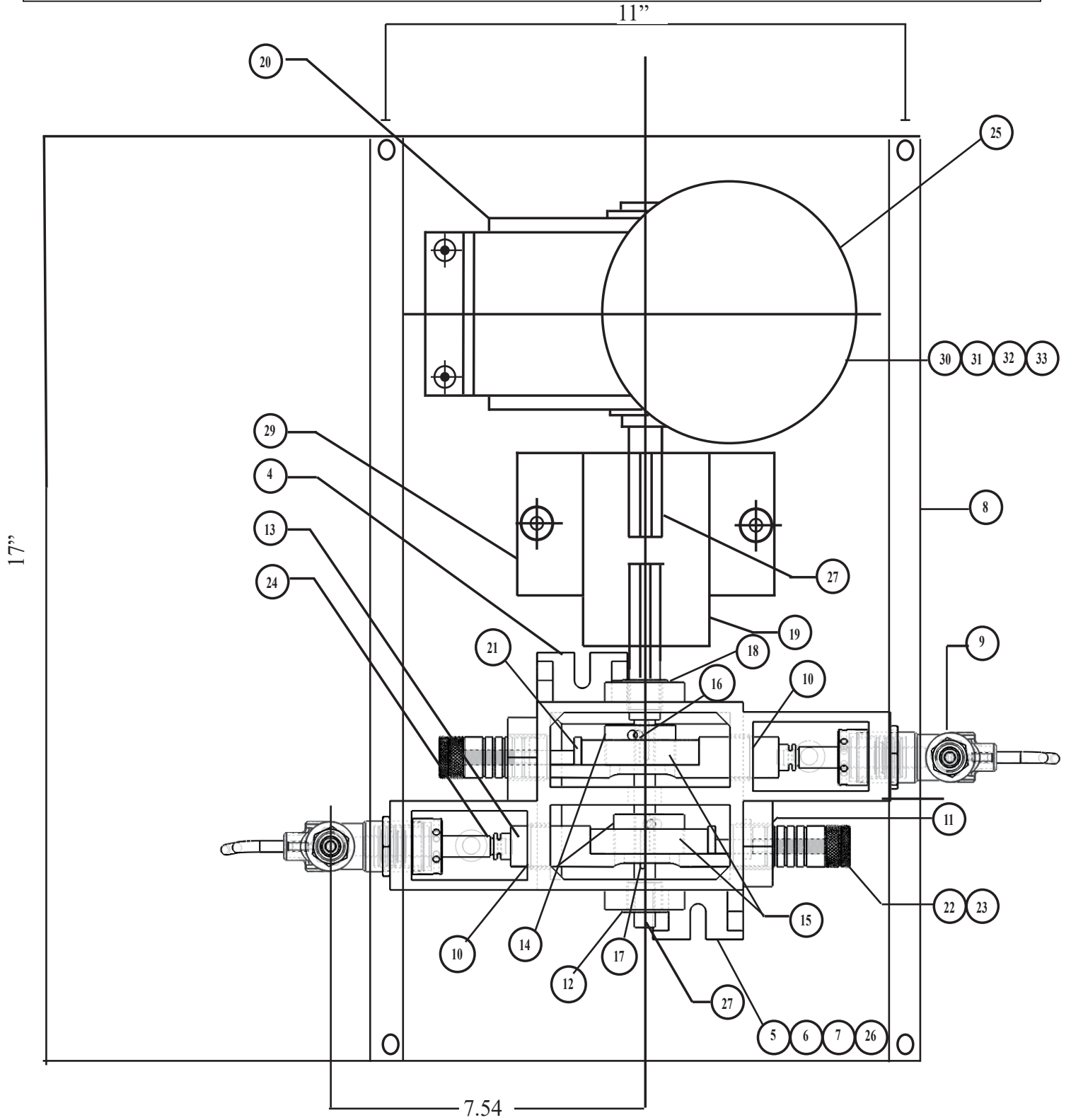

* For Installation and Operating Instructions See page 10

Internal View

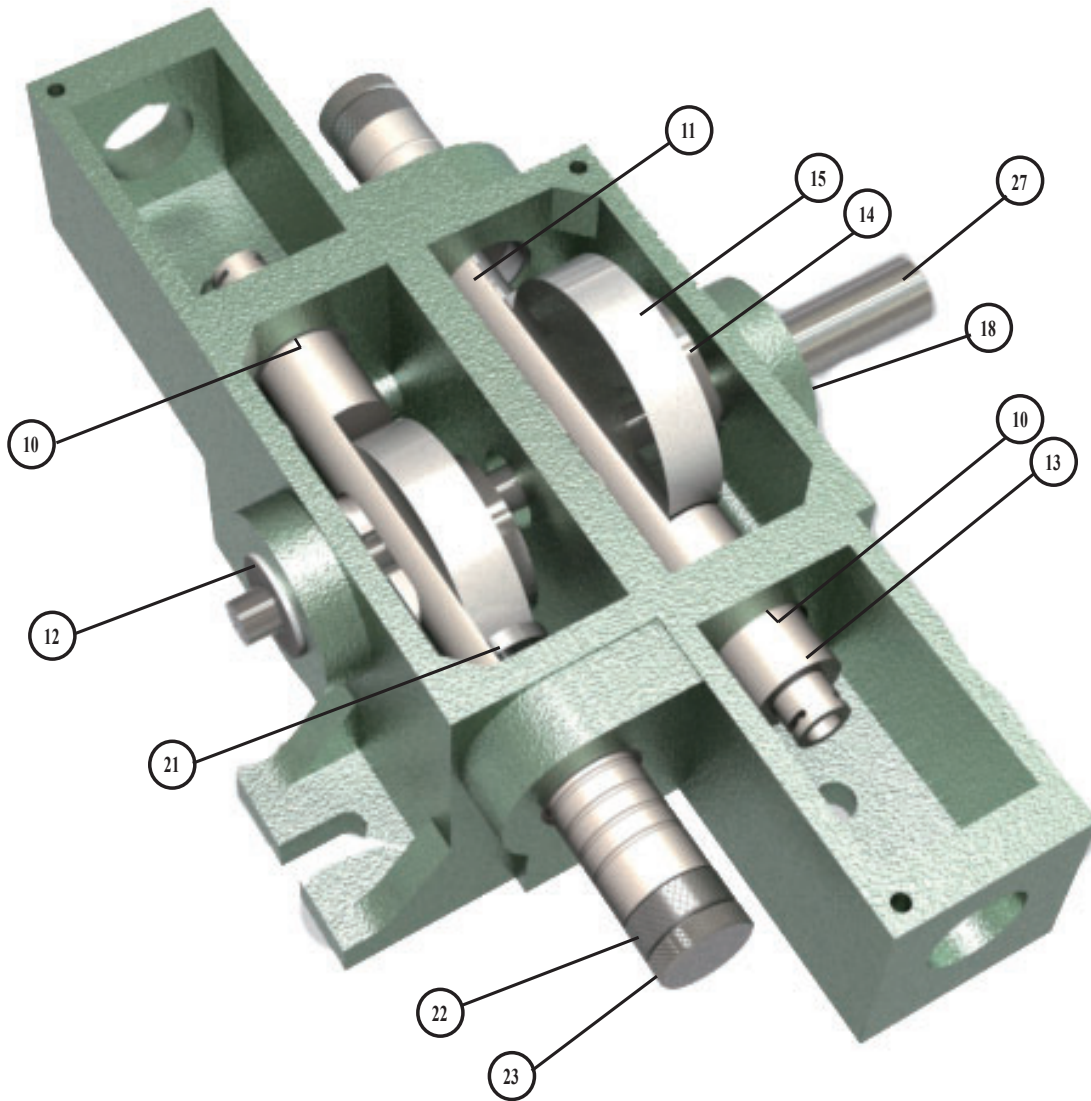

Item	Flomore Part #	Pcs Required	Description	Material
10	D-5964	2	Cross Head Bearing	Nylon
11	D-5965	2	Cross Head Bearing	Nylon
12	A-6935	1	Sleeve Bearing	Nylon
13	B-1542	2	Cross Head	316 SS
14	A-5823	2	Eccentric Cam	C1018 Steel
15	A-5830	2	Roller Bearing	Steel
18	A-6936	1	Sleeve Bearing	Nylon
21	A-5822	2	Stroke Adjustor	C1213 C.R.S
22	A-5824	2	Lock Nut, Stroke Adj.	416 SS
23	A-5825	2	Adjusting Screw	416 SS
27	B-1726.2	1	Drive Shaft	Steel

** This table corresponds with parts list table on page 4*

3500 Duplex Components

A-0675 & A0676 Line Check

Parts List

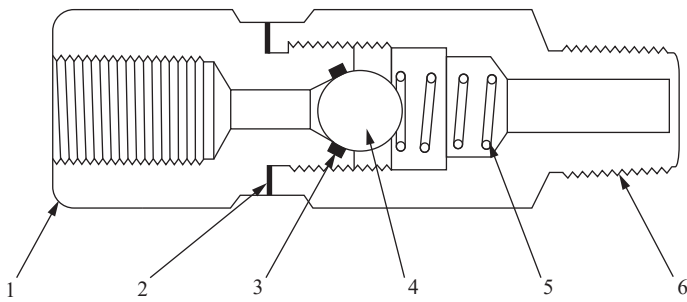

Item #	Part #	# Reqd.	Description	Material
1	A-0678	1	Inlet Body	Brass
	A-1297	1	Inlet Body	303 Stainless Steel
2	A-1574	1	Washer	304 Stainless Steel
3	A-0479	1	O-Ring	Buna-N
	A-2580	1	O-Ring	Viton
4	A-0054	1	3/8" Ball	316 Stainless Steel
5	A-0391	1	Spring	Steel
6	A-0679	1	Outlet Body	Brass
	A-1296	1	Outlet Body	303 Stainless Steel

* Recommended Spare Parts

**A-0675 Only

***A-0676 Only

Electric Motors

Flomore Part #	Horse Power	Enclosure Type	Phase	Voltage	Frequency
A-5896	.5	TEFC	1	115/230	60 hz
A-5897	.5	Explosion Proof	1	115-230	60hz
A-5898	.5	TEFC	3	230-460	60hz
A-5899	.5	Explosion Proof	3	230 1/460	60hz

Injector Heads

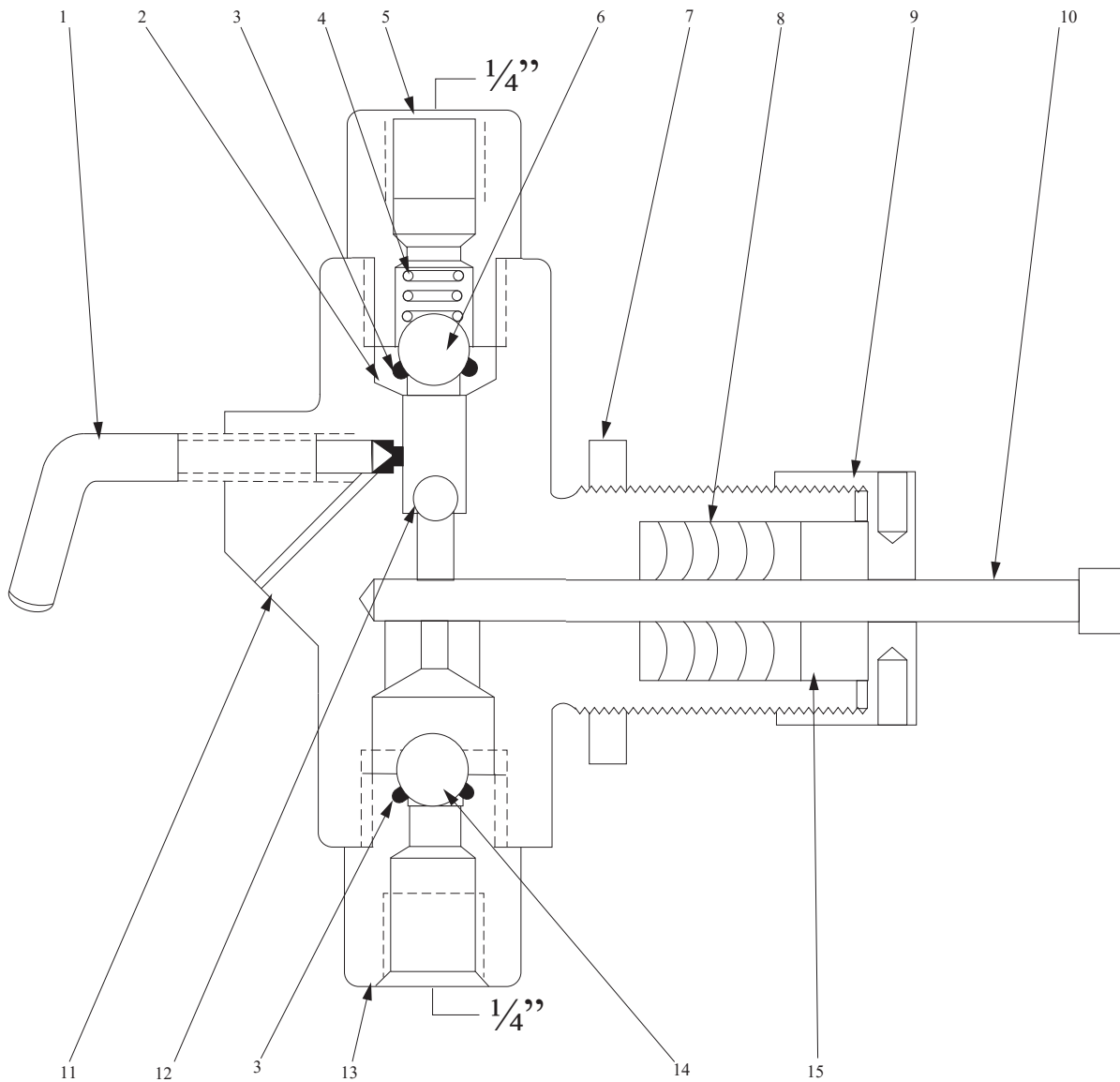

Plunger Packing Chart

<i>Material</i>	<i>Maximum Discharge Pressure (PSIG)</i>			
	<i>3/16"</i>	<i>1/4"</i>	<i>3/8"</i>	<i>1/2"</i>
Buna-N		1500	1500	1500
Viton		3500	3500	3500
Hard		6000	6000	3500
Teflon		1500	1500	1500
Super Duty	6000	4000	1800	1025

Injector Heads

Parts List

Item #	Part #				# Req'd.	Description	Material
	3/16"	1/4"	3/8"	1/2"			
♦	♦	B-0166-0	B-0203-0	B-0496-0	1	Head Assembly	Ductile Iron with Stainless Steel Trim
	B-1560-0	B-1557-0	B-1558-0	B-1559-0			All Stainless Steel
1	A-4027	A-1497			1	Priming Valve	303 Stainless Steel
* 2	B-0737				1	Top Seat Assembly- Buna	303 Stainless Steel
* 3	A-0479				1	Suction & Discharge O'Ring	Buna-N
4	A-0077				1	Ball Check Spring	316 Stainless Steel
5	A-1496				1	Top Bushing	303 Stainless Steel
6	A-0054				1	3/8" Large Top Ball	316 Stainless Steel
7	A-0225				1	Locknut	Brass
* 8	A-3969	A-1461	A-1456	A-0959	1	Plunger Packing	Buna-N
9	A-4104				1	Plunger Packing Gland Nut	303 Stainless Steel
10	A-7001	A-7004	A-7002	A-7003	1	Plunger	17-4 pH Stainless Steel
11	♦	C-0275	C-0276	C-0272	1	Body	Ductile Iron
	C-2040	C-0291	C-0425	C-0349			Stainless Steel
12	♦	A-0126			1	1/4" Small Top Ball	316 Stainless Steel
* 13	B-1216	B-0736			1	Bottom Seat Assembly-Buna	303 Stainless Steel
* 14	A-0054				1	3/8" Suction Ball	316 Stainless Steel
15	A-4332	A-1463	A-0957	A-1219	1	Plunger Packing Gland	303 Stainless Steel
16	A-0126	♦			1	1/4" Ball	316 Stainless Steel
17	A-4394	♦			1	Suction Bushing Sealing Washer	304 Stainless Steel

Alternate Construction

Item #	Part #	Description	Material
2	A-0806	Top Seat Assembly (Metal-to-Metal)	303 Stainless Steel
2	B-0843	Top Seat with Viton O'Ring	303 Stainless Steel
3	A-2580	O'Ring	Viton
8	♦	3/16" Plunger Packing	Hard
	A-3967		Viton
	A-3966		Teflon
	A-2295	1/4" Plunger Packing	Hard
			Viton
			Teflon
			Hard
			Viton
	A-1642	3/8" Plunger Packing	Viton
			Teflon
			Hard
			Viton
A-1875	1/2" Plunger Packing	Hard	
		Viton	
		Teflon	
A-4101			
A-1234			
A-1874			
A-4103			
A-1012			
* 13	A-0771	Bottom Seat Assembly (Metal-to-Metal)	316 Stainless Steel
13	B-0844	Suction Bushing with Viton O'Ring	303 Stainless Steel
* 14	A-0053	1/2" Suction Ball	316 Stainless Steel

**Recommended Spare Parts*

***Items must be used together*

Installation and Operating Instructions

Installation

1. Plan Ahead for proper mounting, pump location is very important. position it to provide efficient routing of suction, discharge lines and electric service.

- Avoid long suction lines and provide for a flooded suction line whenever possible.

2. Pump fluid lines, connections operate best when there is a minimum restriction to the medium flow.

3. Install the proper electrical starters and disconnect switches

- It is recommended that a solid mounting support be provided--
- take advantage of factory installed holes in the base plate for securing the pump

Fluid End

4. All fluid connections both suction and discharge, should be sealed tight.

- Fluid end connections are 1/4" NPT
- The suction connection is at the bottom of the fluid end, and the discharge connection is at the top.

Motor

5. A conduit connection is provided at the motor for electrical connections.

- Assure the proper electrical service has been provided.
- Assure all connections are tight, in their proper location, properly grounded and fused

Gear Reducer

6. Check the oil level of the gear reducer

- If the oil level is below the output shaft oil plug, refill to the plug with API approved oil

Start Up

7. Open the priming valve on the fluid end assembly and start the pump motor

8. Allow the pump to run until a clear bubbleless stream of media comes out of the priming valve

9. Close the priming valve

10. Check the packing for proper sealing.

- If it leaks, stop the pump and make necessary adjustments. Adjust the stroke adjustment knob to obtain the desired flow rate

Preventive Maintenance

11. Check periodically (min once per month) and apply small amount of grease to the cam bearing and to the crosshead areas that cycle through the linear bearings

- Check the packing regularly. If leakage is observed, stop the pump.
- Make small adjustments by turning the gland nut.
- Restart the pump but do not over tighten the packing as this will reduce the packing life and possibly damage the plunger.

*****It is always important to assure the packing material is compatible with the media being pumped, check for swollen or deteriorated seals.***

FLOMORE

Richart Distributors, Inc.

Corporate Office

3415 South I-35 Service Road

Oklahoma City, OK 73129

1-866-843-5654

Fax: (405) 619-3007

Richart@flomore.com

Dickinson Branch

533 East Villard Suite B

Dickinson, ND 58601

(701) 483-8267

Fax: (701) 483-8268

Kilgore Branch

Cardon Sales Company, LLC

820 South Commerce Street

Kilgore, TX 75662

(903) 984-3070

Fax: (903) 984-7901

THunt@cardonsales.com

Louisiana Branch

Cardon Sales Company, LLC

213 Cummings Road

Broussard, LA 70518

(337) 839-1704

Fax: (337) 839-1706

bcardon@cardonsales.com

Odessa Branch

Patterson Equipment Sales, Inc.

1610 S. Regal Avenue

Odessa, TX 79763

(432) 332-3345

Fax: (432) 332-3348

chad@pattersonsalesinc.com

